

GLOBAL JOURNAL OF ADVANCED ENGINEERING TECHNOLOGIES AND SCIENCES**A REVIEW OF UNIDIRECTIONAL LINK IN MULTIHOP MANETs****Mian Wisal Ahmad*, Dr. Majid Ashraf**

* Department of Electrical Engineering, University of Engineering and Technology Peshawar, Pakistan

DOI: 10.5281/zenodo.1467621**ABSTRACT**

Mobile ad hoc networks [MANETs] are a set of mobile nodes that are communicating with one another via wireless links without having any existing infrastructure. MANETs pose many challenges in terms of routing, due to their mobile nature of nodes, fixed transmission power and constantly changing topologies. A node in a MANET may not directly reach every other node, it is possible that the packet from source to destination may need to follow a multiple wireless links. As a result, the links might affect, and a unidirectional link can incur in MANETs. The capacity of network can be reduced due to the ignorance of unidirectional links and it can also lead towards network partitioning. The concerns of such types are very much relevant to MANETs, where the transmission power and bandwidth are limited, and the links are not necessarily always bidirectional. In this paper, many protocols are reviewed for the problem of unidirectional/asymmetric links in MANETs.

KEYWORDS: MANETs, Unidirectional links, WLAN, MAC.**INTRODUCTION**

In past, a lot of wireless networks were wireless local area networks (WLAN), the WLAN was operating on IEEE 802.11 WIFI protocol in infrastructure mode. A base station is the prime object of infrastructure network also called the access point. The access point is the propriety of a company. The infrastructural network is also called centralized network and the communication channel is controlled by base station. The base station also connects the WLAN to a company network or to internet. A second mode of IEEE 802.11 is ad-hoc networks, these networks are broadly used in military applications, emergency operations, conferencing and personal area networks [1]. This mode of communication does not require a fixed infrastructure and nodes in the networks communicates with one another directly. The nodes in wireless ad-hoc network acts as a transceiver (transmitter as well as receiver). The multi-hop ad-hoc networks are the extended version of wireless ad-hoc networks. In multi-hop ad-hoc networks, nodes can communicate through wireless communication channel. These channels are digital packet radios. As there is a limited transmission range of radios, therefore, the nodes might not have connected directly with one another and the network may need intermediate nodes for forwarding packets. The intermediate nodes act like relays between sender and receiver node. The originating packet from the sender goes through many intermediate nodes before finally reaching to the destination node. This concept of networking was applied successfully in many classes of networks that penetrates the mass market [2]. The various forms of networks are mobile ad-hoc networks, wireless sensor networks, mesh networks, vehicular networks, delay tolerant networks, hybrid networks etc. are being largely used in civilian and military applications. Mobile Ad-hoc Networks (MANETs) are low cost networks because it does not relay on existing infrastructure. MANETs also offers a high potential throughput. Due to these characteristics, the MANETs are usually considered as a very promising technology soon. Unidirectional link is a problem of routing in MANET often neglected by researchers, unidirectional link is formed due to unequal transmission range of nodes or due to an interfering node. In this paper, the problem of unidirectional link is reviewed. This paper also reviews a few mechanisms on which unidirectional links are tackled. The rest of the paper is organized as follows. Section 2 defines background of MANETs. Section 3 describes the research gap in MANETs. Section 4 reviewed some mechanisms on which unidirectional links could be tackled. Finally, section 5 concludes the paper and present the future work.

BACKGROUND

In 1970's, by the development of Advance Research Project Agency's (ARPA), multi-hop multiple access Packet Radio Network (PRNET) program in 1972 [3], needed the packet switch network without fixed infrastructure.

In 1980's, 2nd G was formed in which the packet switch networks were independent of an infrastructure. This led the PRNET towards development, which was the part of a program called Survivable Adaptive Radio Networks (SURAN). SURAN had a vital role in the applications of military services. [4].

In 1990's, the ad hoc networks were developed which were used to connect wireless computers and various other devices. In the late 1990's and early 2000's, the wireless local area network got the popularity and the commercial application like Bluetooth was introduced.

The aim of the 4th G MANETs was to provide ultra-high speed of 100 Mbps at any location. It was efficient and cheaper as compared to 3G networks.

MANETs are widely used by military forces or department of disaster management in the affected areas where the infrastructure is completely collapsed. There are other various examples like student teacher interaction during lecture.

MANETs:

MANET [6] is a decentralized and robust network which is formed by communication of mobile nodes with one another. Communication takes place by wireless links without fixed infrastructure [7].

In recent era, wireless communication has rapidly developed. In past, wireless networks communication was formed between hosts and routers only. While in the modern era, in wireless networks, routers can transmit data packets to other nodes as well (source or sink).

According to IETF working group of MANETs 2002 [8], a MANET has a stand-alone system of associated hosts (mobile routers) connected wirelessly. Routers can move and randomly arrange themselves. The topology of MANET is very unpredictable and can change quickly at any time. The network with such characteristics can work either way, in a form of independently operated network or as a part of massive network [9].

Table 1.1: Comparison of MANETs vs Cellular networks.

MANETs	Cellular Networks
<ol style="list-style-type: none"> 1. Non-Infrastructural. 2. Packet switched network. 3. Quick and cost effective. 4. Multi-hop links. 5. Distributed routing. 6. Shared radio channel. 7. Path breaks are frequent. 8. Time synchronization is difficult. 9. Built in properties of maintenance in the networks (self-organization). 10. Aim of routing is to find minimum overhead paths and to reconfigure broken paths. 	<ol style="list-style-type: none"> 1. Fixed infrastructure. 2. Circuit switched network. 3. High time deployment and cost. 4. Single-hop links. 5. Centralized routing. 6. Dedicated bandwidth. 7. No frequent path breaks. 8. Time synchronization is easy. 9. Network maintenance cost is high. 10. Routing aim is to minimize call drop ratio and maximize call acceptance ratio.

Overview of MANETs:

A temporary network formed by mobile nodes independent of fixed infrastructure.

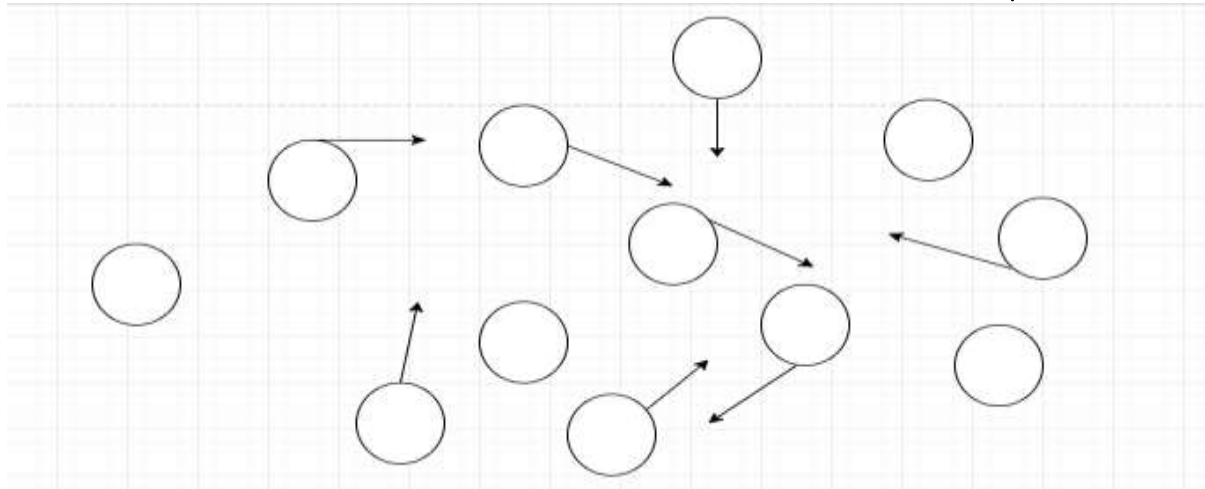

Figure 2.1: Mobile Nodes moving with random speed and direction

The random behavior of nodes can be seen in Figure 2.1. The nodes organize themselves in the up and running network. Transmission is traversed through the nodes; a packet goes through many intermediate nodes to reach to the destination. At the same time all the nodes behave as a host and a router. The topology of ad hoc network is dynamic in nature i.e. the reason why nodes are in constant motion and continuously change their position.

Characteristics of MANET

MANETs have various features as compared to other networks [10].

- **Multi-Hopping:**

The data transmission takes places through wireless channels. The data is sent out from the sources nodes, traversed through intermediate nodes which are there for relaying purposes, to the destination nodes. Multiple hops are taken by the packet due to short transmission range.

- **Energy Conservations:**

In MANETs, energy conservation is very important due to the limited supply of energy.

- **Security:**

MANETs are comparatively less secure than infrastructural based network and can be easily spoofed or hacked.

- **Dynamic Topology:**

Due to the unpredictable and arbitrary movement of nodes, a dynamic topology is needed that quickly adapts and predict changes.

- **Self-Organization:**

In MANETs, there is no central administration. Nodes form a network to save neighbor's information and in case of any change occurred, the nodes adapt accordingly with the change and will reorganize.

- **Scalability of MANETs:**

MANETs in comparison to infrastructural or wired network is less scalable due to limited channel capacity.

Applications of MANETs:

There are various applications of MANETs from small to large networks where the situation is independent of infrastructure [7].

- **Emergency Operations:**

In case of any disaster when the centralized infrastructure collapse, MANETs could be very useful for rescue operations.

- **Military Use:**

In the battlefield when making a centralized infrastructure is impossible, MANETs could be extremely important for communication among the forces.

- **Conferencing:**

If a group of employees in a remote location, independent of network infrastructure when called for a conference by head office, MANET could be the only possible way.



- **Personal Area Network (PAN):**

In future, every person will have his own personal network and all these personal networks will communicate with each other. There will be various MANETs that will act and respond to each other.

Issues in MANETs:

There are various issues associated with ad hoc networks, including weak wireless channels, unidirectional links and many propagation properties of wireless links. MANETs have many advantages but there are also some issues associated with it.

- **Interference:**

Interference occurs by the collision of data packets which causes problem in MANET. This happens when two separate source nodes transmit data to same destination node and are unaware of the transmission carried by either node. The data may collide at the destination node which creates interference. These hidden terminals can decrease the throughput and can increase overhead of MAC protocol. MAC protocol works under data link layer which shares the wireless medium in multi-hop MANETs. MAC protocol in MANETs need a control transmission to occur by reducing the hidden terminals to increase the throughput and to decrease interference.

- **Mobility of Nodes:**

Nodes mobility is an important issue to tackle. Nodes in MANETs are transceivers which are constantly in motion resulting in path breaks, change in topology, loops and stale information of routing. Therefore, the routing protocol need to smartly manage the mobility.

- **Routing:**

Communication paths are created by protocols with a limited power. Therefore, the protocol should be able to effectively manage the overhead, path breaks, frequent updates and life time of the wireless links.

2.1.5 Communications in MANETs:

Communications in MANETs are categorized into four streams. [11].

- Broadcast: Information transmitted by a node is received by all the nodes in the network.
- Unicast: For data exchange, two nodes directly communicate with each another.
- Multicast: Data sent by a node is received by more than one node, independent of the sender's location.
- Any-cast: Data sent by a single node is received by more than one node, in a close proximity to the sender.

RESEARCH ISSUES

MANET is a hot topic for research these days due to their no-infrastructure behavior. In MANET, due to broadcasting and shared transmission media, the probability of packet collision is very high. The nodes in MANET, due to high mobility or unequal transmission range, poses a lot of issues like unidirectional links. Apart from routing, there are more research issues in this area like reliability, energy conservation, QoS, scalability, node cooperation, power control, security etc.

The Problem of Unidirectional Links:

MANETs are independent of infrastructure which means that the decisions of routing are distributed among all nodes in participation. Therefore, the connectivity of nodes between one another is a very significant issue. Meanwhile all the links between nodes are radio signals, so connectivity is dependent deeply on Signal to Noise Ratio (SNR), the propagation delay, transmission power, the mobility of nodes etc. Therefore, the properties of nodes differ from one another. Due to which, the nature of links may be asymmetric and the communication that is directed from source to destination may follow the unidirectional path.

The capacity of network can be reduced due to the ignorance of unidirectional links and it can also lead towards network partitioning. The concerns of such types are very much relevant to MANETs, where the transmission power and bandwidth are limited, and the links are not necessarily always bidirectional.

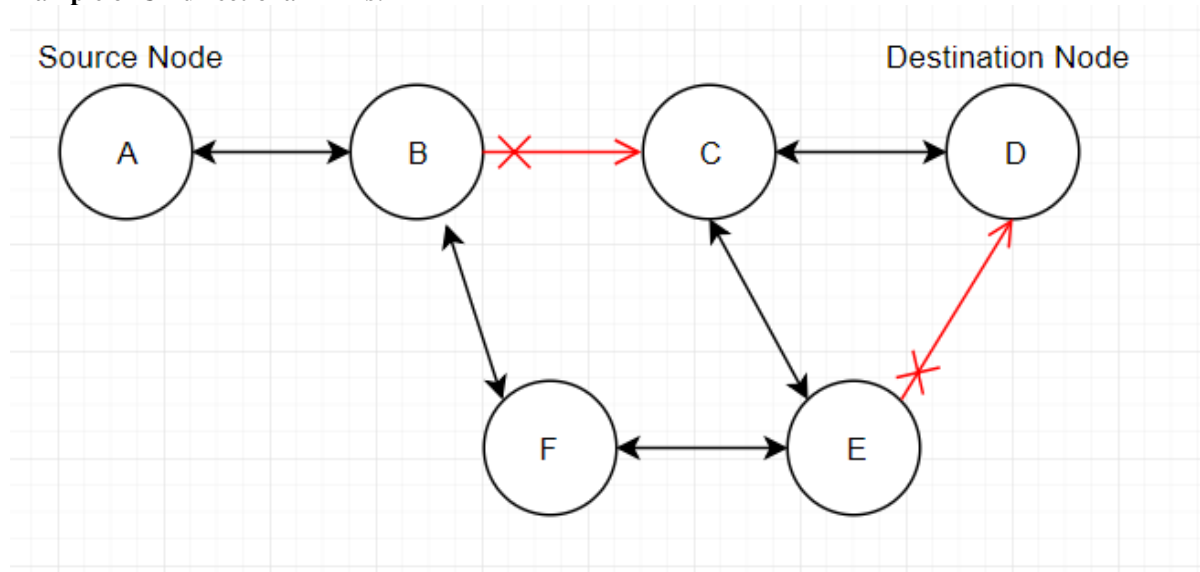
Example of Unidirectional Links:*Figure 3.1: Unidirectional MANET*

By analyzing Figure 3.1, in reactive routing protocols, source node A wants to communicate to the destination node D. Node A sends out a Route Request (RREQ) broadcast packet to every node participating in the network. Every message of RREQ has a unique identity which is defined by source ID and broadcast ID $\langle \text{srcID}, \text{BID} \rangle$. A forward route is created by discovery phase of RREQ which follows the path “A->B->C->D”. It can be realized clearly that the links B-C and E-D are unidirectional because of the unequal transmission range of the nodes. When node D obtains the first copy of RREQ, it caches the $\langle \text{srcID}, \text{BID} \rangle$ and immediately transmits a Reply Packet (RREP) to the node from where the RREQ packet was received (node C). After that, the redundant RREQ packets are checked continuously by node D and if any redundant RREQ packet is received, it is checked and matched with the cache packet. If the packet received matches the packet in cache, it will be dropped. The redundant packet sent out can be seen from Node E to Node D.

According to reactive routing protocol like AODV, node D for sending the RREP packet follows the forward created path in backward direction (in reverse order). D-C-B-A will be the reverse order path of forward route A-B-C-D. But following the backward path is not possible because of asymmetric link existing between node B and node C. In this scenario, at node C, the RREP packet will be dropped and source node A will attempt another RREQ discovery. If source node A, after three request attempts, fails to receive a reply, the `MAX_RREQ_TIMEOUT`, will occur at source node and the whole process will be repeated.

Short Lived Unidirectional Links:

Short lived unidirectional links are made because of the interference of a hidden node. As the name suggests, these links are made up for a short period of time. An outside node interferes with the unidirectional link making it a bidirectional link. The moment this interference from an outside node ceases, the link reverts to unidirectional link.

Long Lived Unidirectional Links:

Long lived unidirectional links usually appear due to the unequal range of transmission power of nodes. These unidirectional links are long lived and remain unidirectional unless these nodes move from one another to completely break the link or transform into bidirectional. This kind of transformation can take place when a short-ranged node and a long-ranged node come in a proximity.

Solutions in the Literature
Gateway Discovery Algorithm:

Figure 4.1: RREQ of Gateway Discovery Protocol

ZHUANG Lin, LIU Yuan-an et al [12] proposed an efficient adaptive gateway discovery algorithm which successfully connects MANET having unidirectional links. AODV protocol is modified in this research. Gateway advertised message and gateway discovery messages are rebroadcasted, both are extended with the information of local connection. From global route computation, the unidirectional links can be easily removed, and the connectivity of internet is enhanced. For better coverage of gateway advertisement, an adaptive scheme was proposed which adjust the broadcast range. It sends interval of gateway advertisement messages according to network conditions. In this scheme, RREQ message will be modified to RREQ-I. In RREQ-I, neighbor's information is appended which came from neighbor's node list (NNL). NNL of each mobile node is maintained by sending periodic hello messages to record its set of neighbors.

Figure 4.1 shows, when a sender node 'S' sends a RREQ packet, it first appends the neighbor's information from NNL. The RREQ packet is modified to RREQ-I. when the in-between node 'A' receives the packet "RREQ-I", it will search the neighbor's info in the RREQ-I. if this node finds itself in neighbor's list, it will conclude that node 'A' can reach node 'S' and node 'S' can reach node 'A'. This means the link between node 'A' and node 'S' is bidirectional. Node 'A' appends its own neighbor's information and will remove the former one from RREQ-I. The packet received by another intermediate node 'C' and it does not find itself in the neighbors' set, the link between node 'A; and node 'C' is considered to be unidirectional. Node 'C' removes this packet without rebroadcasting and will not set up an opposite path to node 'S'. This mean, the unidirectional links cease to exist.

Clustering technique:

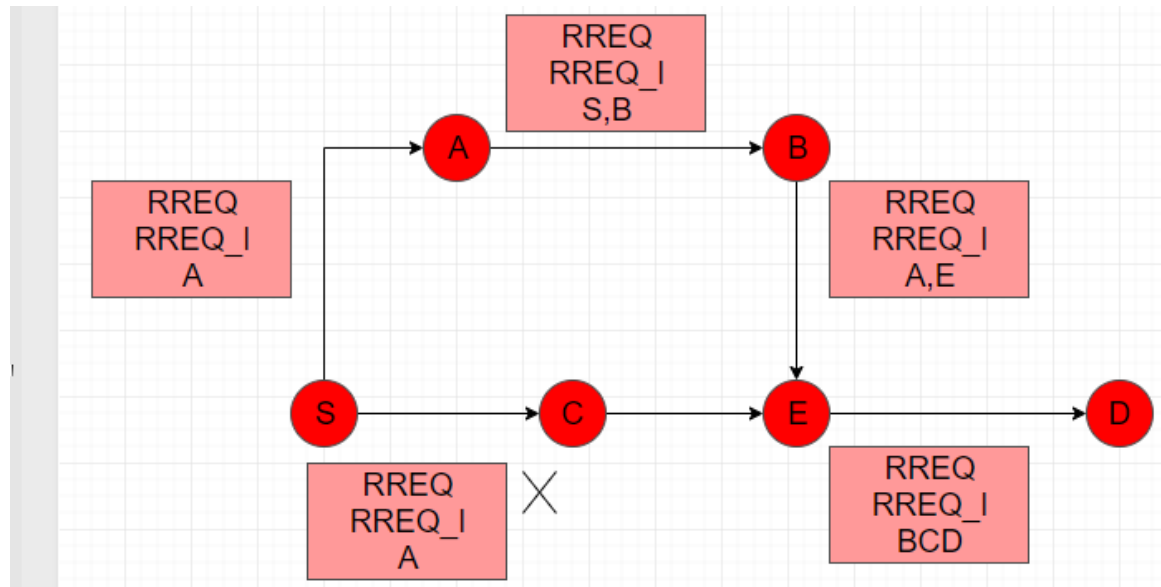
Figure 4.2: Route maintenance in Clustering technique

Yi-Yu su et al [13] proposed a clustering technique by taking advantage of multi-hop acknowledgments to plan an effective hybrid protocol for ad hoc networks, which efficiently tackles asymmetric links. A maintenance scheme is also proposed in this research which ensures stability of routing and clustering of mobile environments. In this scheme, all the nodes of the network are partitioned into clusters, virtually large network is divided into many sub-networks. At every cluster, there are cluster heads and cluster members. The head of the cluster will maintain the cluster members and the information of intra-cluster topology. The cluster members which relate to adjacent clusters are the gateway nodes, as only the heads of cluster maintain the local information of topology, therefore, it improves the performance and reduces the overhead of exchanging routing tables of every node. For unidirectional links, tunneling and multi-hop acknowledgements techniques are proposed which detect unidirectional links and the relationship maintained with unidirectional neighbors.

Figure 4.2 shows the working of clustering algorithm, as nodes in MANETs are mobile, there is a chance that the established route may inactive. Therefore, a route maintenance is mandatory to successfully ensure the deliveries of packets. According to Figure 4.2, a route 1-2-3-6-5-12-13-15-16-17 is established from source node 1 to destination node 17. Node 5 ensures that the link between node 5 and node 12 is unidirectional. Therefore, it informs its CH (cluster head) for local repair. CH will perform a local repair which means to find another path to reconnect the next cluster of original path. If there are gateway nodes in the cluster which can reach to another cluster of the original route, the local repair mechanism will forward the packets to gateway nodes to reach to next cluster. Local RREQ is issued when the cluster finds a gateway node. Local RREQ merely communicates to the adjacent clusters, if the path reconnects, the overhead for the reconstruction of new path is prevented. In case the original path does not reconnects by adjacent clusters, a Route Error (RERR) packet is sent back to sender node and a global RREQ will be allotted for the construction of new path. Therefore, the route is reconnected by adjacent clusters and a new route 1-2-3-4-7-8-11-12-13-14-16-17 is established.

Reverse Path Search Strategy:

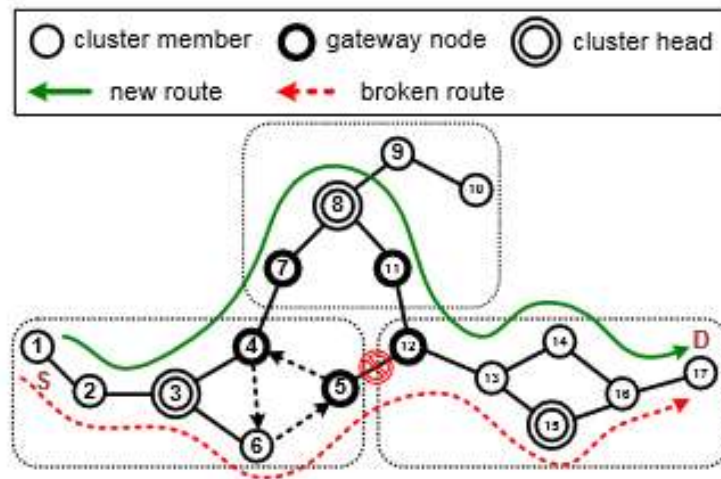
Figure 4.3: Demonstration of Reverse Path Search Strategy.

M.K Marina et al [14] proposes a search strategy of reverse route for bypassing asymmetric links. Over several multipaths, routes are generated through bidirectional links only. The routing table of every node contains several reverse paths. If Route Reply Packet (RREP) does not transport due to unidirectional link, the reverse route is removed and RREP is sent on the alternate reverse paths. When all the alternate routes get exhausted, it searches backtracks to previous hop and identical procedure is recurred till at least a bidirectional link is found.

As shown in Figure 4.3, in the RREQ flood phase, it is noticed that multiple reverse route to source node S are found. It is also evident, that some reverse paths are suffering from unidirectional links like the path C-A-S. The RREP propagation through C-A-S is not possible due to unidirectional link between A-S causing the transmission of a new packet called Backtrack Route Reply (BRREP) at node A. Node C removes the reverse path through A and sends the RREP to node B for exploring the opposite path i.e. C-B-S. The C-B-S path also fails as there is a unidirectional path between C-B causing node C to send BRREP. Node E removes the opposite path through node C and sends the RREP packet to node F for exploring another path. Therefore, E-F-G-H-S path should be successfully explored. This is a reliable technique, but it takes a huge time to find a route and produces huge link layer overhead.

CONCLUSION

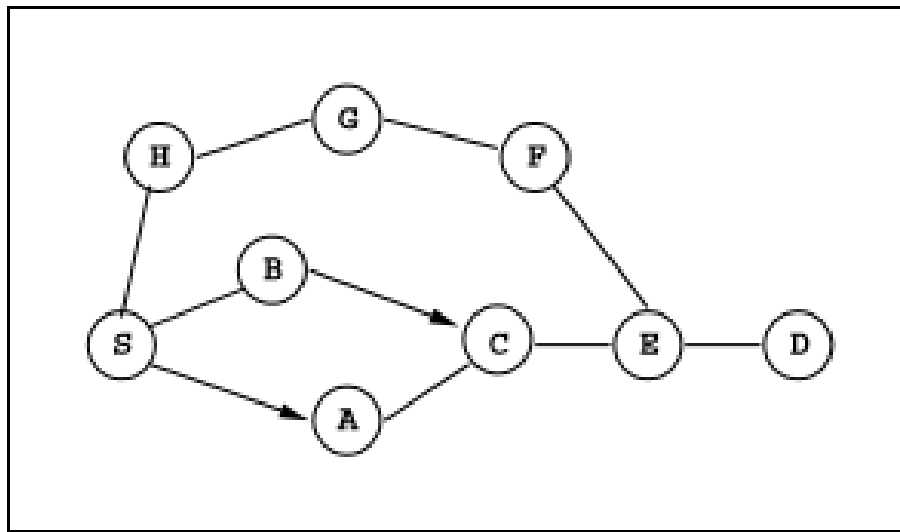
In Mobile Ad-hoc networks (MANETs), researchers usually assume that nodes are same in their characteristics like signal-to-noise ratio (SNR) and transmission range. In real life scenario, these assumptions are false, because the characteristics of node is greatly influenced by power consumption, location and mobility. In bidirectional links, some existing protocols are restricted equally, and implicit symmetrical paths are in their operation. For MANETs, many routing protocols are proposed so far but in most of the cases, the researchers ignore the fact that there might be unidirectional links in the network. The ignorance of unidirectional links usually affects the performance metrics of network like end2end delay, packet delivery ratio and routing load. It also sometimes exhibits the issues of connectivity.

ACKNOWLEDGEMENTS

I owe my profound gratitude to my thesis supervisor Dr. Majid Ashraf, Assistant Professor, University of Engineering and Technology, Peshawar for his valuable guidance, supervision and persistent encouragement. Due to the approach adopted by him in handling my research and the way he gave me freedom to think about different things, I was able to do constructive research. By working under him I have gained priceless knowledge as to how to go about doing an effective research.

REFERENCES

- [1] Grossglauser, Matthias, and David NC Tse. "Mobility increases the capacity of ad hoc wireless networks." *IEEE/ACM transactions on networking* 10, no. 4 (2002): 477-486.
- [2] Gupta, Piyush, and Panganmala R. Kumar. "The capacity of wireless networks." *IEEE Transactions on information theory* 46, no. 2 (2000): 388-404.
- [3] Toh, Chai K. *Ad hoc mobile wireless networks: protocols and systems*. Pearson Education, 2001.
- [4] Al-Omari, Saleh Ali K., and Putra Sumari. "An overview of mobile ad hoc networks for the existing protocols and applications." *arXiv preprint arXiv:1003.3565* [2010].
- [5] IEEE 802 LAN/MAN Standards Committee. "Wireless LAN media access control [MAC] and physical layer [PHY] specifications." <http://standards.ieee.org/getieee802/> [2009].
- [6] Vir, Dharm, S. K. Agarwal, and S. A. Imam. "Quantitative analyses and evaluation of MANET routing protocols in effect of varying mobility model using Qual-Net simulator." In *Information and Communication Technologies [WICT], 2012 World Congress on*, pp. 915-921. IEEE, 2012.
- [7] Herberg, Ulrich, and Thomas Clausen. "A comparative performance study of the routing protocols load and rpl with bi-directional traffic in low-power and lossy networks [In]." In *Proceedings of the 8th ACM Symposium on Performance evaluation of wireless ad hoc, sensor, and ubiquitous networks*, pp. 73-80. ACM, 2011.
- [8] Boukerche, Azzedine, ed. *Algorithms and protocols for wireless, mobile Ad Hoc networks*. Vol. 77. John Wiley & Sons, 2008.
- [9] Basagni, Stefano, Marco Conti, Silvia Giordano, and Ivan Stojmenovic, eds. *Mobile Ad Hoc networking: the cutting edge directions*. Vol. 35. John Wiley & Sons, 2013.
- [10] Deepa, S., and GM Kadhar Nawaz. "Mobility and density aware AODV protocol extension for mobile adhoc networks-MADA-AODV." *Journal of Computer Science* 8, no. 1 [2012]: 13.
- [11] Zhuang, Lin, Yuan-an Liu, Kai-ming Liu, Lin-boZhai, and Y. A. N. G. Ming. "An adaptive algorithm for connecting mobile ad hoc network to Internet with unidirectional links supported." *The Journal of China Universities of Posts and Telecommunications* 17 [2010]: 44-49.
- [12] Su, Yi-Yu, Shiow-Fen Hwang, and Chyi-Ren Dow. "An Efficient Cluster-Based Routing Algorithm in Ad Hoc Networks with Unidirectional Links." *Journal of Information Science & Engineering* 24, no. 5 [2008].
- [13] Marina, Mahesh K., and Samir R. Das. "Routing performance in the presence of unidirectional links in multihop wireless networks." In *Proceedings of the 3rd ACM international symposium on Mobile ad hoc networking & computing*, pp. 12-23. ACM, 2002.